



# TYPHOON INTAKE SYSTEMS

## INSTALLATION INSTRUCTIONS

**69-6000**

**MAZDA**

**1999-05 Miata**

**L4-1.8L**

**NOTE: E.O.# D-269-30 APPLIES to 1998-2004 MODEL YEARS ONLY**

**TOOLS NEEDED:**

- Flat Blade Screwdriver
- Phillips screwdriver
- Needle Nose Pliers
- 4mm Allen Wrench
- Ratchet
- 6" Ratchet Extension
- 14" Ratchet Extension
- 10mm Socket
- 12mm Socket

**PARTS LIST:**

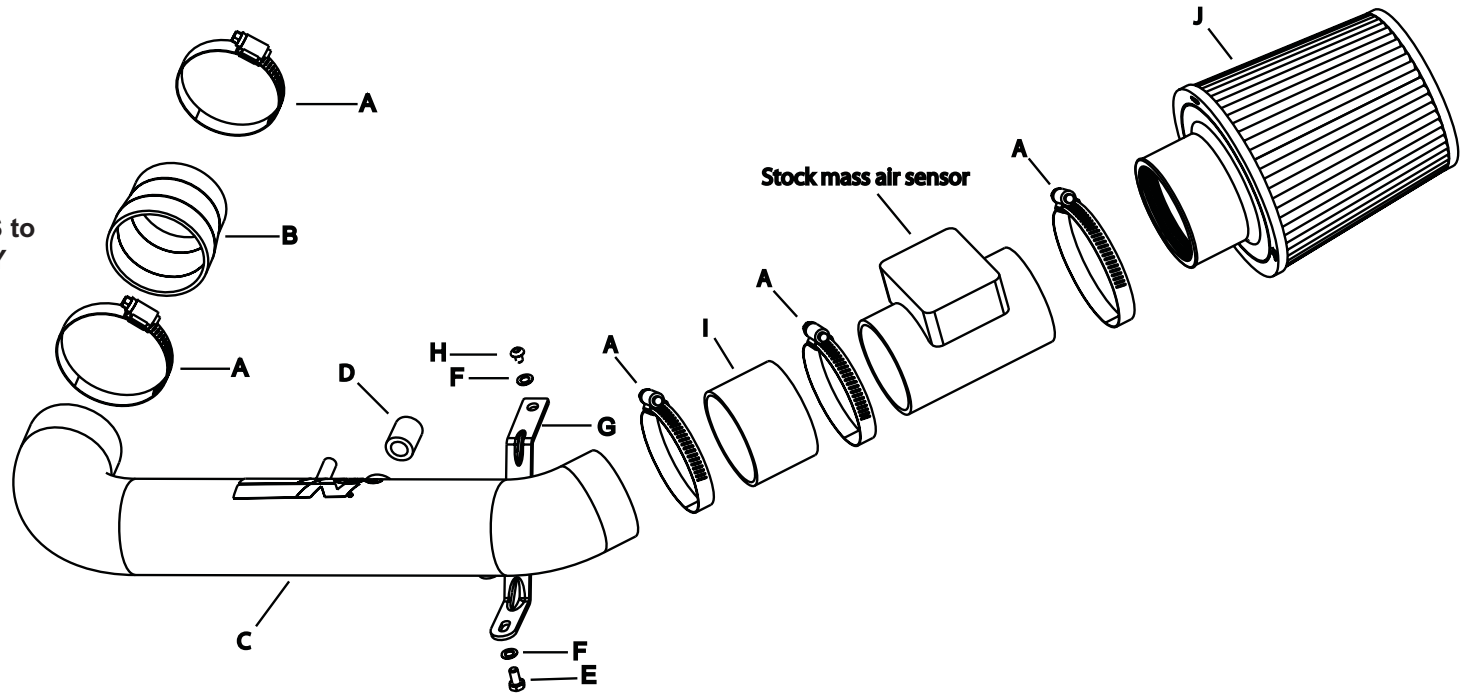

Desc.	Qty.	Part #	Desc.	Qty.	Part #
A Hose Clamp, #44	5	08560	F Wave Washer	2	08277
B Silicone Step Hose, Black	1	084016	G Bracket "Z"	1	070031
C Typhoon Intake Tube	1	27085	H Bolt, 6mm x 12mm L.	1	07727
D Hose, 17/32"ID x 11/16"	1	084054	I Silicone Hose, Black	1	08440
E Bolt, 6mm x 16mm L.	1	07730	J Air Filter	1	KRU4870E

**NOTE: FAILURE TO FOLLOW INSTALLATION INSTRUCTIONS AND NOT USING THE PROVIDED HARDWARE MAY DAMAGE THE INTAKE TUBE, THROTTLE BODY AND ENGINE.**

**TO START:**

1. Turn the ignition OFF and disconnect the vehicle's negative battery cable.

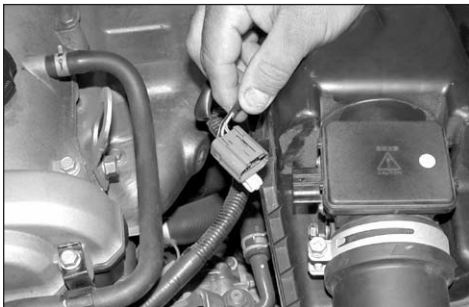

2. Disconnect the mass air sensor electrical connection as shown.

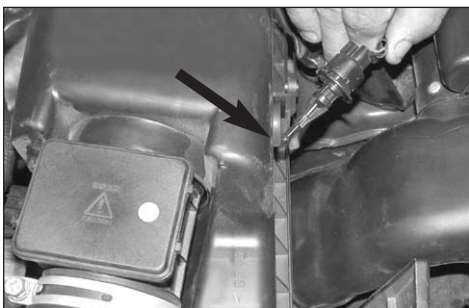

3. Remove the air temperature sensor from the air cleaner assembly as shown.

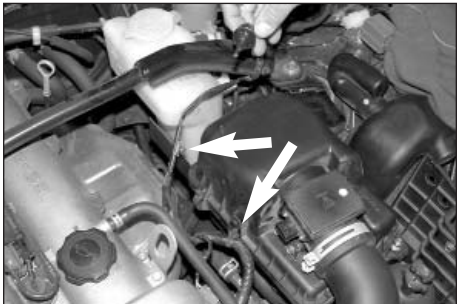

4. Unclip the air temperature sensor electrical connection from the air cleaner assembly as shown.

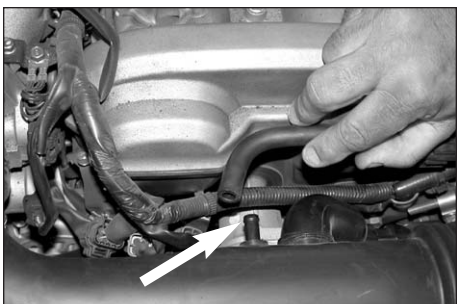

5. Disconnect the crank case vent hose from the stock intake tube as shown.



6. Loosen the hose clamps at the throttle body and at the mass air sensor, then remove the stock intake tube as shown.



7. Loosen and remove the bolt that secures the air inlet duct to the inner fender, then remove the air inlet duct as shown.

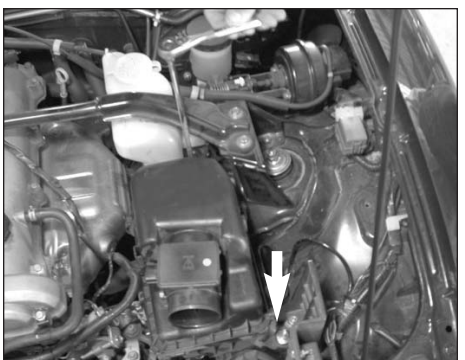

8. Loosen and remove the hex bolt and nut that secure the air cleaner assembly as shown.



9. Pull upwards to remove the air cleaner assembly as shown.

**NOTE: K&N recommends that customers do not discard factory air intake.**

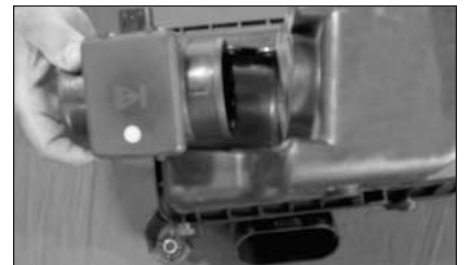

10. Loosen and remove the two bolts that secure the mass air sensor, then remove the mass air sensor as shown.

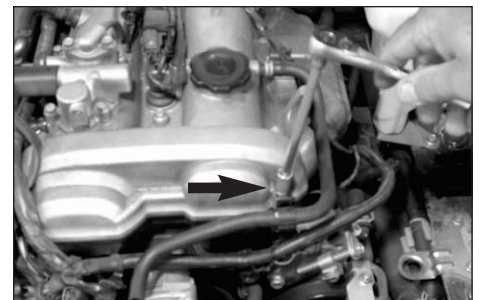

11. Remove the bolt that secures the crank case vent hose bracket to the cam cover as shown.



12. Install the silicone step hose and hose clamps onto the K&N Intake Tube as shown.



13. Install the silicone straight hose and hose clamps onto the K&N Intake Tube as shown.

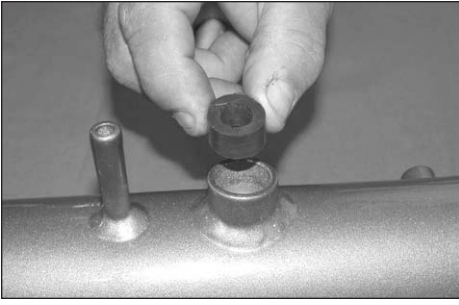

14. Install the silicone sleeve into the air temperature sensor bung on the K&N Intake Tube as shown.

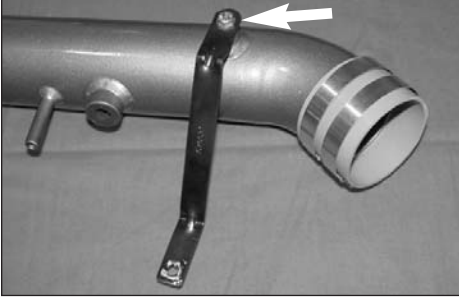

15. Install the "Z" bracket onto the K&N Intake Tube using the provided hardware as shown.



16. Install the K&N Intake Tube onto the throttle body, then, line up the bracket with the threaded hole from step 11.

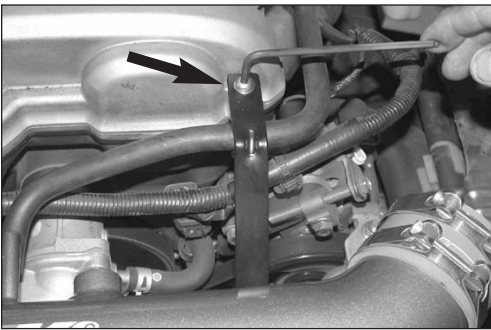

17. Using the provided hex bolt secure the bracket to the cam cover as shown.



18. Slide the mass air sensor into the silicone hose, then, tighten all hose clamps as shown.

**NOTE: The arrow on the side of the mass air sensor specifies the correct direction of the air-flow into the engine.**



19. Install the K&N Air Filter onto the mass air sensor, then, tighten the hose clamp as shown.



20. Tighten the hex bolt on the K&N Intake Tube as shown.

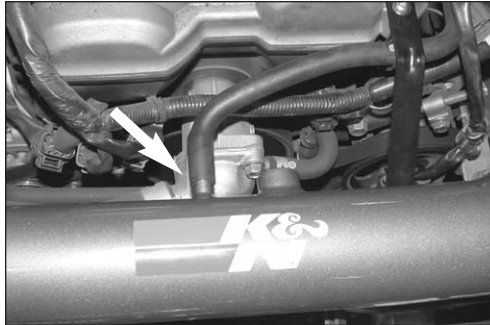

21. Install the crank case vent hose onto the K&N Intake Tube as shown.

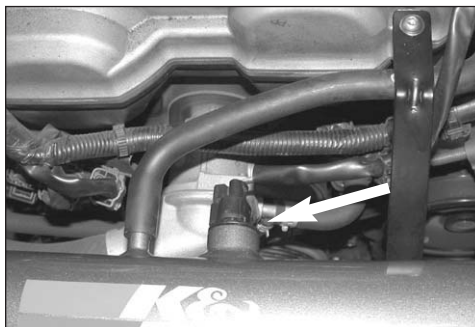

22. Slide the air temperature sensor into the bung on the K&N Intake Tube as shown.

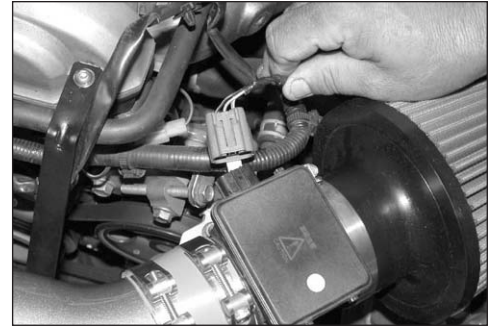

23. Reconnect the mass air sensor electrical connection as shown.



24. Reconnect the negative battery cable and double check to make sure everything is tight and properly positioned before starting the vehicle.

25. The C.A.R.B. exemption sticker, (attached), must be visible under the hood, so that an emissions inspector can see it when the vehicle is required to be tested for emissions. California requires testing every two years, other states may vary.

26. It will be necessary for all Typhoon's to be checked periodically for realignment, clearance and tightening of all connections. Failure to follow the above instructions or proper maintenance may void warranty.

#### ROAD TESTING:

1. Start the engine with the transmission in neutral or park, and the parking brake engaged. Listen for air leaks or odd noises. For air leaks secure hoses and connections. For odd noises, find cause and repair before proceeding. This kit will function identically to the factory system except for being louder and much more responsive.

2. Test drive the vehicle. Listen for odd noises or rattles and fix as necessary.

3. If road test is fine, you can now enjoy the added power and performance from your kit.

4. K&N suggests checking the air filter element periodically for excessive dirt build-up. When the element becomes covered in dirt (or once a year), service it according to the instructions on the Recharger service kit, part number 99-5000 or 99-5050.