

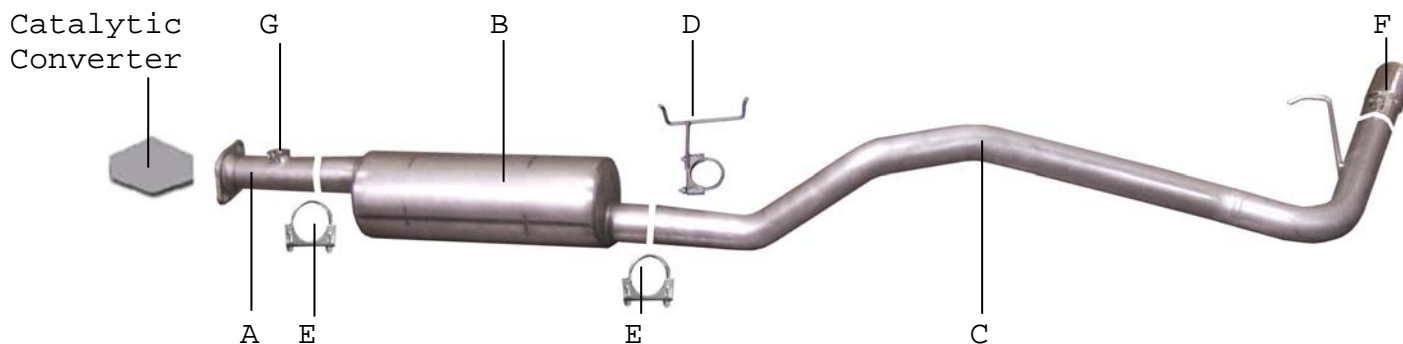

INSTRUCTION MANUAL

CAT-BACK SINGLE EXHAUST

00-04 TOYOTA TACOMA TRUCK 2.4L 2WD STANDARD CAB, SHORT BED PART # 18700



ITEM	PART #	QTY	DESCRIPTION
A	700292	1	2-1/2" HEADPIPE W/ FLANGE #GP-126
B	788200	1	SUPERFLOW MUFFLER
C	700129	1	2-1/2" TAILPIPE W/ HANGER
D	4131	1	REAR MUFFLER HANGER
E	5757	2	2-1/2" CLAMP
F	500361	1	3" STAINLESS TIP
G	BOLT KIT FOR O2 SENSOR		
		2	O2 SENSOR LOCK WASHER
		2	O2 SENSOR BOLT
		2	O2 SENSOR NUT

Thank you for purchasing our GIBSON EXHAUST SYSTEM for your vehicle. If you need further assistance, please do not hesitate to call our Technical Department at (800) 528-3044, Monday through Friday, 8:00 am to 5:00 PM. **0903**

INSTALLATION INSTRUCTIONS

PART #18700

WHEN INSTALLING THIS EXHAUST SYSTEM, MAKE SURE TO USE PROPER SAFETY PRECAUTIONS. USE JACK STANDS WHEN UNDER THE TRUCK, BLOCK TIRES AND USE SAFETY GLASSES AND GLOVES. DO NOT WORK WITH HOT PIPES!

SUGGESTED TOOLS

14MM SOCKET & WRENCH, 9/16" SOCKET & WRENCH, 12MM & 7/16 SOCKET & WRENCH, JACKSTAND, HACKSAW

LAY OUT THE GIBSON EXHAUST ON THE FLOOR SO IT LOOKS LIKE THE DRAWING AND COMPARE PART NUMBERS WITH THE MANUAL. THEN REMOVE THE FACTORY O2 SENSOR LOCATED IN FRONT OF THE MUFFLER. APPLY A SMALL AMOUNT OF WD-40 TO THE BOLTS. **UN-BOLT THE FLANGE IN FRONT OF THE MUFFLER. DO NOT DISCARD STOCK NUTS & BOLTS YOU WILL RE-USE THEM. AND REMOVE THE FACTORY EXHAUST (DO NOT DAMAGE THE FACTORY GASKETS YOU WILL RE-USE THEM).** LEAVE ALL FACTORY RUBBER GROMMETS IN PLACE. FOR EASIER REMOVAL CUT OFF YOUR STOCK EXHAUST BEHIND THE MUFFLER.

USING FACTORY NUTS, BOLTS, AND GASKET INSTALL HEADPIPE #A. THE WELDED O2 SENSOR FLANGE WILL BE POSITIONED ON THE PASSENGER SIDE OF THE HEADPIPE. USING FACTORY GASKET RE-INSTALL THE O2 SENSOR. DO NOT USE GASKET SFAI FR

SLIP MUFFLER #B ONTO HEADPIPE #A NO MORE THEN 2" AND NO LESS THEN 1". THE MUFFLER INLET WILL HAVE THE INSIDE LOUVERS FACING FORWARD. THE OUTLET OF THE MUFFLER WILL BE POSITIONED AT 12 O'CLOCK. USE A JACK STAND TO SUPPORT THE MUFFLER.

SLIP THE OVER AXLE PIPE #C INTO THE OUTLET OF THE MUFFLER NO MORE THEN 2" AND NO LESS THEN 1". USE CLAMP # E TO SECURE TAILPIPE TO MUFFLER. DO NOT TIGHTEN. INSERT WELDED HANGER INTO RUBBER GROMMET.

INSTALL HANGER #D INTO THE REAR MUFFLER RUBBER GROMMETS. THE VERTICAL RODS WILL BE FACING TOWARDS THE REAR OF THE TRUCK.

NEXT INSTALL YOUR STAINLESS STEEL TIP TO YOUR DESIRED LOOK. USE ANY ALUMINUM OR STAINLESS STEEL CLEANER TO POLISH YOUR TIP. THEN TIGHTEN ALL CLAMPS AND HANGERS

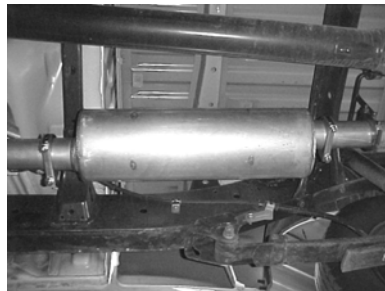
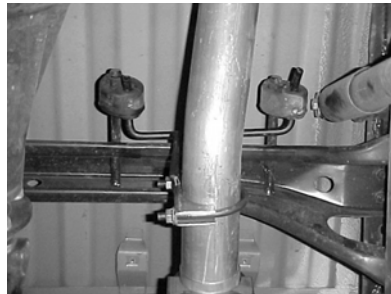
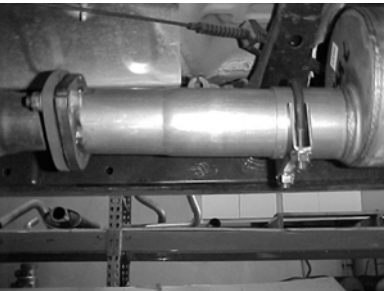
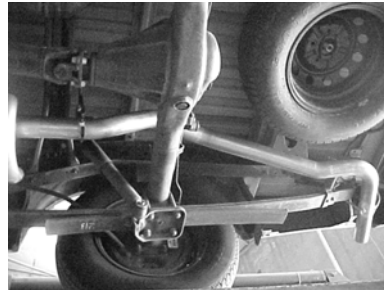

"MAKE SURE YOU HAVE A MINIMUM OF A 1" CLEARANCE ON ALL PIPES FROM ALL RUBBER BRAKE LINES, TIRES, SHOCKS, FUEL LINES, ETC."