

Toyota 4DR 4Runner

Set Part # 31913

Rev D 04-23-08

Step 1:

Prior to Installation:

- A) **Fit:** Verify the fit of the flares to vehicle. (Some filing, sanding, or cutting may be necessary to ensure proper fit).
- B) **Painting:** (Optional) if paint is desired it must be done prior to installing flares on the vehicle clean outer surface with a good grade degreaser. **DO NOT USE LACQUER THINNER OR ENAMEL REDUCER AS A DEGREASER.** Wipe outer surface thoroughly with a tack rag prior to paint.
Paint flares using a high quality enamel, or polyurethane automotive paint. (Application of a primer coat is optional)
If painting edge trim (not recommended), use a flex additive.
- C) **Performance:** Using larger Tires may increase the area required to turn the vehicle. Some Tire/Rim combinations may require lowering bump stops and or installing steering stops to prevent tire from contacting flare.
- D) **Exhaust System:** Modifications may be necessary to maintain a minimum 4" clearance between flares and exhaust pipes. (Exhaust gases should not vent directly onto flares)



TOOLS FOR EASY INSTALLATION

- Electric Drill
- Duct Tape
- Jack and Jack Stands (optional)
- Pop Rivet Gun
- Grease Pencil
- 3/16", 5/16", and 11/64" Drill Bit

FLARE INSTALLATION PROCEDURES

Step 2: Edge Trim Installation (See Illustration #1)

- A) Remove factory installed edge trim when necessary.
- B) Peel two to three inches of red vinyl backing away from edge trim tape. Applying the adhesive side of the edge trim to the inner side of the flare, affix the edge trim to the top edge of the flare (the portion that comes in contact with the vehicle). **See Illustration #1**
- C) Press edge trim into place along the top edge of the flare in one-foot increments, pulling red vinyl backing free as you continue to work your way around the top edge of the flare.

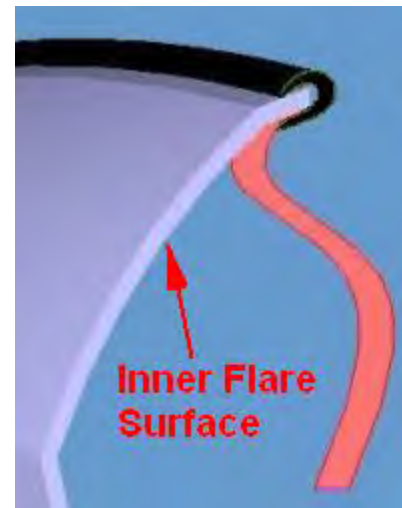

Illustration #1

Step 3: Preparing the Work Area

- A) Support and remove wheel using jack and jack stands (optional).
- B) Remove and save screws securing mud flaps, factory fender trim, and factory running board end boots (when installed). For vehicles with factory running boards, replace end boots with Bushwacker Running Board Boots, 35-16001-11, sold separately.

Step 4: Flare Installation (Front) (See Illustrations #2 & #3)

There are two parts to each front flare: the bumper cap and the body flare.

- A) Remove and save top forward three screws securing the fender to the fender liner.
- B) Drill three 3/16" holes at the top most positions and four 5/16" holes at the lower positions marked by indentations on the inside of the body flare.
- C) Using drill-tip screws, attach three stainless steel brackets to the body flare at the three top most holes drilled in Step 4C. Position flare on fender and **loosely** secure using screws removed in Step 3B and 4A, and two screws supplied with kit. **See Illustrations #2 & #3.** Tighten screws holding brackets to the flare first, then tighten remaining screws to vehicle.
- D) Remove protective paper backing from one side of a double-stick tab and press into position on the upper inside surface of the bumper cap. **See Illustration #2.**
- E) Remove the remaining protective paper from the double-stick tab and place the bumper cap in position on the bumper aligned with body flare.
- F) Drill three 9/64" holes for rivets with kit supplied drill bit at the points marked by indentations on the flare as indicated in **Illustration #2.**
- G) Secure bumper cap to bumper using two non-slotted aluminum rivets and one slotted aluminum rivet.

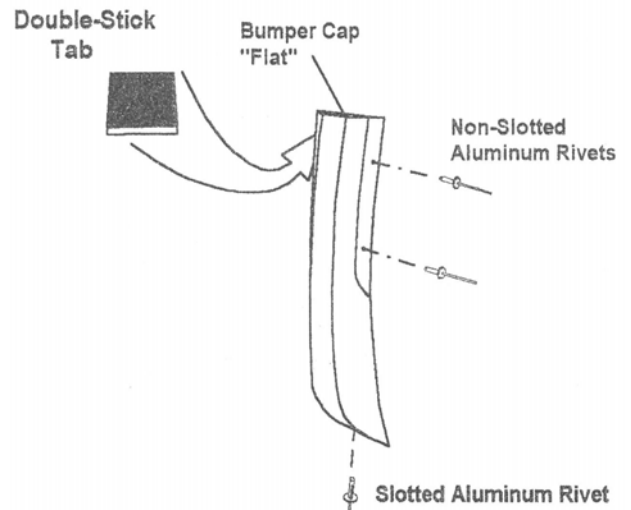

Illustration #2

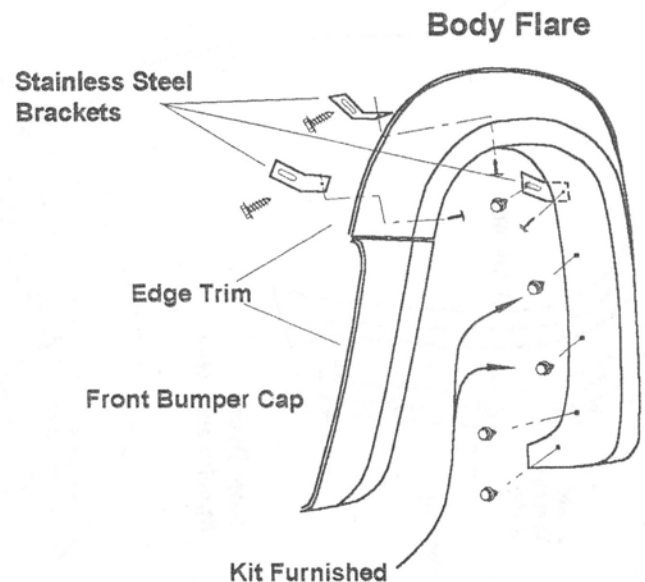

Illustration #3

Step 5: Flare Installation (Rear) (See Illustrations #4 - 7)

There are four parts to each rear assembly: the inner and outer door parts, the center part, and the bumper cap.

- A) Tape the matching inner door part inside the outer door part. Apply two double-stick tabs to the side of the inner door part, which lies against the door. **See Illustration #4.**
- B) Tape center and bumper cap parts in position on fender and bumper. Press the combined inner and outer door parts in position on the door leaving a gap of approximately 1/8" between wheel well rim and flare to allow for proper door operation. Confirm part to part and part to door seam alignment. **See Illustration #4.**
- C) Remove outer door and bumper cap parts only. Leave inner door and center parts in position.
- D) While applying slight pressure to the outside of the center flare, install four supplied drill tip screws through the center flare and into the sheet metal at the points marked by indents along the inner flare flat which lies against the wheel well rim. **See Illustration #5.**

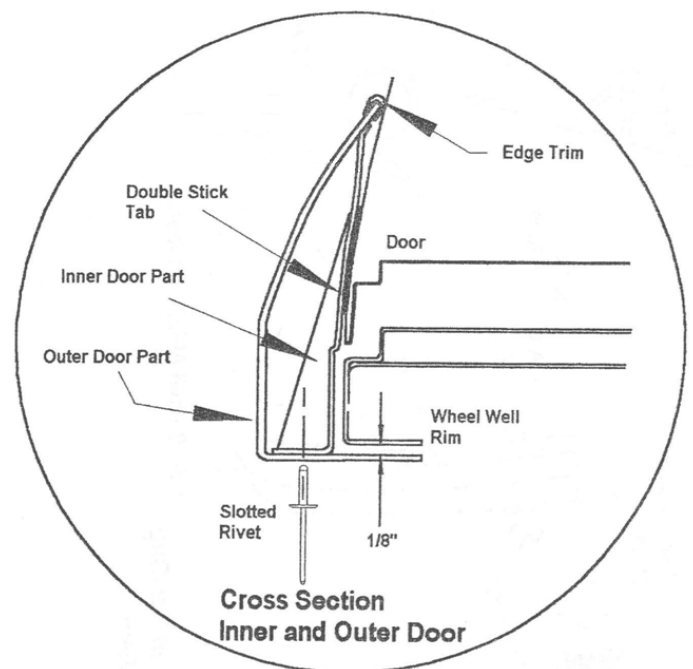

Illustration #4

- E) Drill three 5/16" holes at the indents along the inside flat of the bumper cap.
- F) Remove protective paper backing from one side of a double-stick tab and press on top inside surface of the bumper cap flat near the edge.
- G) Remove the remaining protective paper from the double-stick tab and place the bumper cap in position on the bumper. Secure cap using three original equipment screws removed in Step 3B.
- H) Install a supplied drill tip screw through lower rear surface of the bumper cap and into the bumper.
- I) Remove inner door part from door and remove double-stick tabs placed in Step 5B. Replace inner door part and install five supplied drill tip screws through the inner door part and into the door at positions marked by indents. **See Illustration #6.**
- J) Place outer door part over inner door part and drill five 11/64" holes at positions marked by indents. Secure outer to inner door part using five "slotted" aluminum rivets. **See Illustration #7.**

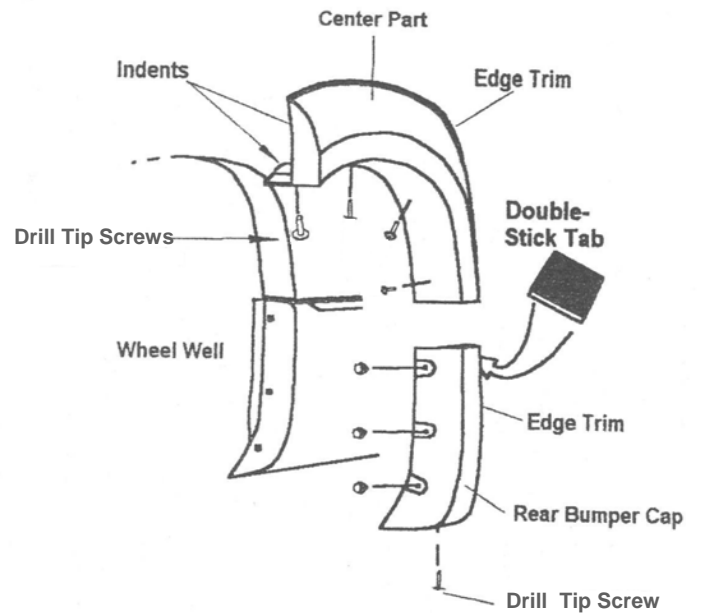

Illustration #5

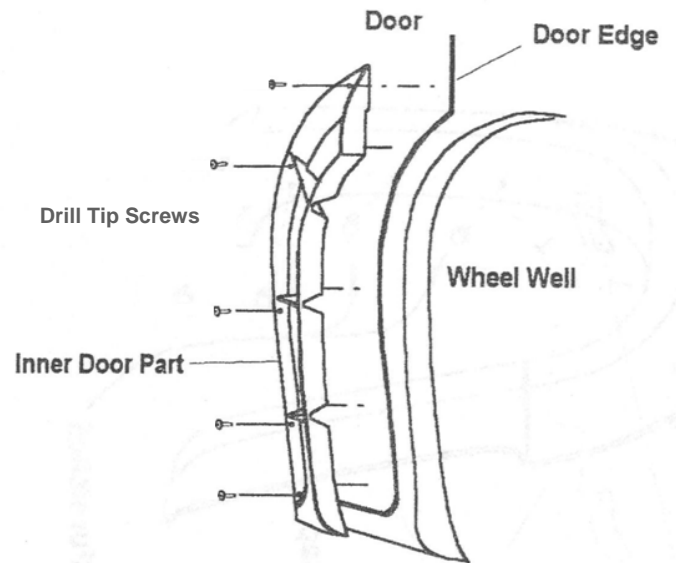

Illustration #6

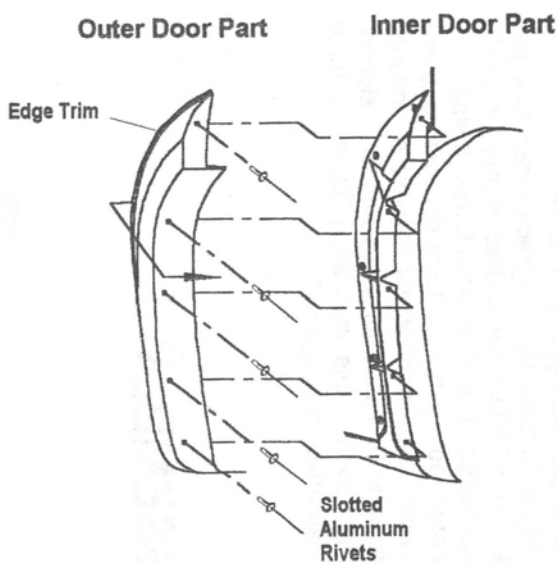

Illustration #7

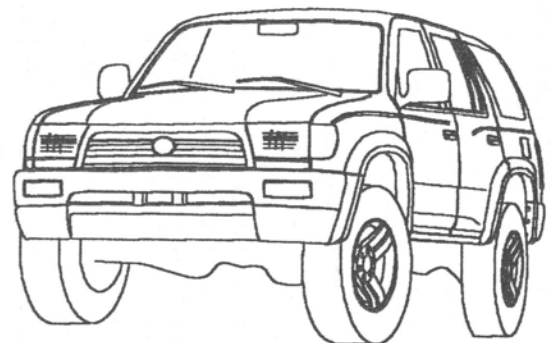

Illustration #8