

INSTALLATION INSTRUCTIONS

77-2561 FORD/MAZDA

2004-07 RANGER / B4000
V6-4.0L

NOTE: This kit was not designed to fit vehicles with a body lift.

TOOLS NEEDED:

Ratchet
Extension
7mm Socket
10mm Socket
13mm Socket
9/16" Socket
9/64" Allen Wrench
Flat Blade Screwdriver

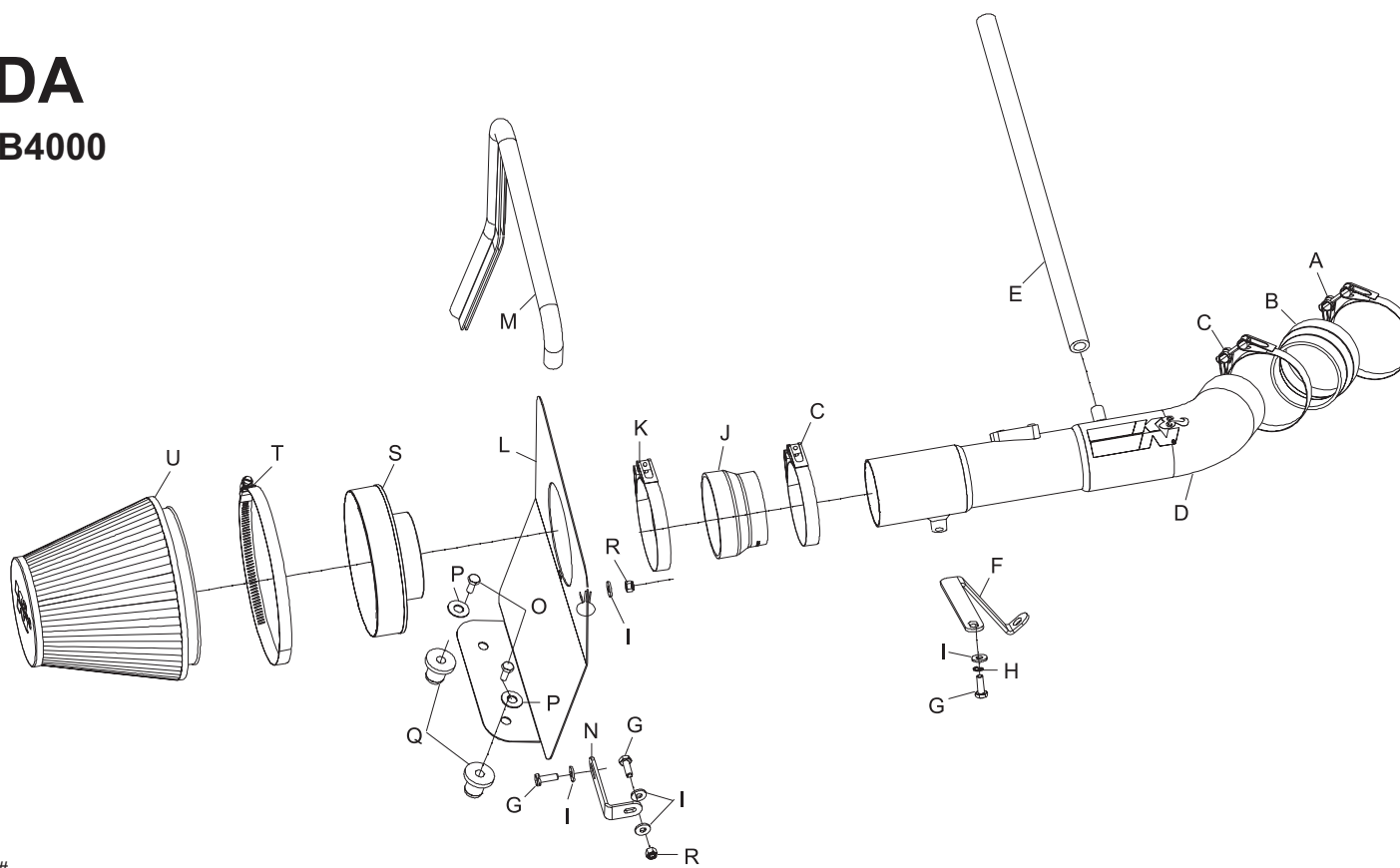

PARTS LIST:

Desc.	Qty.	Part#	Desc.	Qty.	Part#	Desc.	Qty.	Part#
A hose clamp #52	1	08610	G bolt; 6mm-1.00 x 16mm hex	3	07703	M edge trim 26"	1	102488
B hose; silicone step	1	084034	H washer; 1/4" id split lock	1	08198	N bracket; sm. "L"	1	070742
C hose clamp #40	2	08554	I washer; 1/4" flat	5	08275	O bolt; 3/8"-16 x 1.25", hex	2	07779
D intake tube	1	27433	J hose; silicone step	1	084034	P washer; 3/8" flat	2	08134
E hose; 1/2" id x 17" l, silicone	1	08177	K hose clamp #64	1	08648	Q inserted nut	2	08163
F bracket; lg "L"	1	010081	L heat shield	1	07488	R nut; 6mm nylock	2	07553
						S adapter #380	1	21512
						T hose clamp #104	1	08697
						U Air filter	1	RF-1048

NOTE: FAILURE TO FOLLOW INSTALLATION INSTRUCTIONS AND NOT USING THE PROVIDED HARDWARE MAY DAMAGE THE INTAKE TUBE, THROTTLE BODY AND ENGINE.

TO START:

1. Turn the ignition OFF and disconnect the vehicle's negative battery cable.



2. Disconnect the mass air sensor electrical connection and separate the harness from the stock intake tube wiring harness clip.



3. Remove the three engine cover mounting bolts shown.



4. Remove the engine cover from the engine.



5. Depress the green locking tab and disconnect the crankcase vent line from the valve cover as shown.



6. Loosen the hose clamp which secures the intake tube to the throttle body, release the two clam shell clamps which secure the upper air box lid and then remove the air box lid and intake tube from the vehicle.



7. Pull firmly up on the lower air box housing to dislodge from the mounting grommets and remove lower air box from the vehicle.

NOTE: K&N recommends that customers do not discard factory air intake.

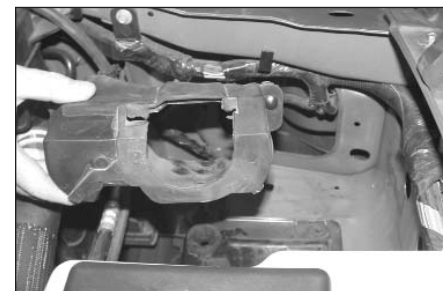

8. Pull firmly on the air inlet duct to dislodge it from core support and remove from the vehicle.

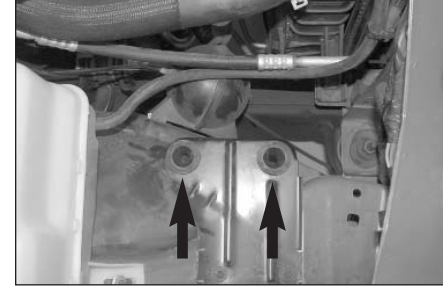

9. Remove the two air box mounting grommets from the mounting plate shown.



10. Install the silicone hose (084034) onto the throttle body and secure with the provided hose clamp as shown.



11. Using the "TORX" wrench provided, remove the mass air sensor from the stock air box assembly as shown.

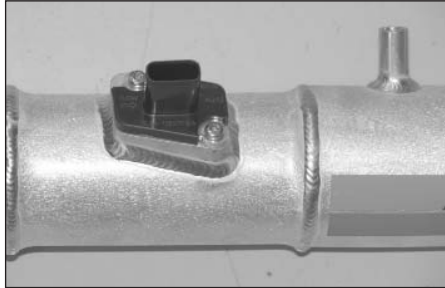

12. Using the factory mounting screws, install the mass air sensor into the intake tube as shown.



13. Install the provided tube mounting bracket (010081) onto the K&N intake tube with the provided hardware as shown.

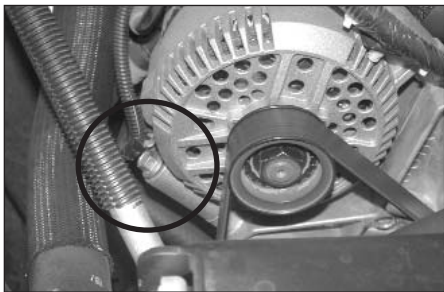

14. Remove the front lower alternator mounting bolt shown.



15. Install the K&N intake tube into the throttle body and secure the bracket in place on the alternator with the bolt removed in step #14



16. Install the heat shield mounting bracket (070742) onto the heat shield with the provided hardware as shown.



17. Install the provided edge trim onto the heat shield as shown.

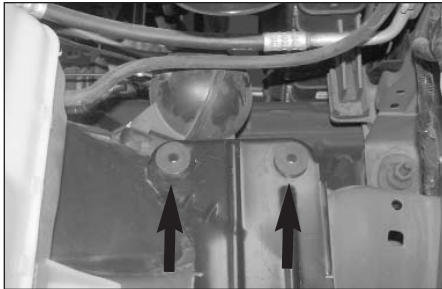

18. Install the two provided threaded inserts into the lower air box mounting plate as shown.



19. Install the heat shield assembly into the vehicle so the bracket lines up with the factory hole in the core support and the holes in the heat shield line up to the inserts installed in step #18. Secure the heat shield with the provided hardware.



20. Install the provided crank case vent hose onto the fitting at the valve cover then attach the other end to the port on the K&N intake tube.



21. Reconnect the mass air sensor electrical connection.



22. Install the provided adapter into the K&N Air filter and secure with provided hose clamp as shown.

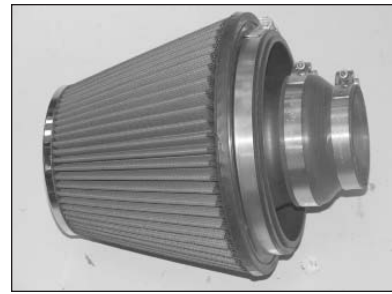

23. Install the provided silicone hose (084034) onto the Air filter assembly and secure with the provided hose clamp as shown.

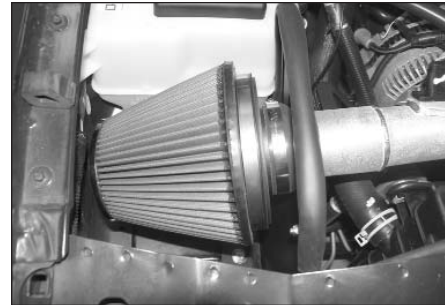

24. Install the Air filter and secure with hose clamp provided.



25. Reinstall the engine cover and secure with the factory mounting bolts.



26. Reconnect the negative battery cable and double check to make sure everything is tightened and properly positioned before starting the vehicle.

27. The C.A.R.B. exemption sticker, (attached), must be visible under the hood so that an emissions inspector can see it when the vehicle is required to be tested for emissions. California requires testing every two years, other states may vary

28. It will be necessary for all intakes to be checked periodically for realignment, clearance and tightening of all connections. Failure to follow the above instructions or proper maintenance may void warranty.

ROAD TESTING:

1. Start the engine with the transmission in neutral or park, and the parking brake engaged. Listen for air leaks or odd noises. For air leaks secure hoses and connections. For odd noises, find cause and repair before proceeding. This kit will function identically to the factory system except for being louder and much more responsive.

2. Test drive the vehicle. Listen for odd noises or rattles and fix as necessary.

3. If road test is fine, you can now enjoy the added power and performance from your kit.

4. K&N suggests checking the Air filter element periodically for excessive dirt build-up. When the element becomes covered in dirt (or once a year), service it according to the instructions on the Recharger service kit, part number 99-5050 or 99-5000.