

# Jeep CJ-5, 6, 7 52-86 Jeep Square Fender 40-64 Set Part # 10010 Rev C 5-06

## Step 1: Prior to Installation:

- A) **Fit:** Verify the fit of the flares to vehicle by holding over the factory flares. (Some filing, sanding, or cutting may be necessary to ensure proper fit).
- B) **Painting:** (Optional) if paint is desired it must be done prior to installing flares on the vehicle clean outer surface with a good grade degreaser. **DO NOT USE LACQUER THINNER OR ENAMEL REDUCER AS A DEGREASER.** Wipe outer surface thoroughly with a tack rag prior to paint. Paint flares using a high quality enamel, or polyurethane automotive paint. (Application of a primer coat is optional) If painting edge trim (not recommended), use a flex additive.
- C) **Performance:** Using larger Tires may increase the area required to turn the vehicle. Some Tire/Rim combinations may require lowering bump stops and or installing steering stops to prevent tire from contacting flare.
- D) **Exhaust System:** Modifications may be necessary to maintain a minimum 4" clearance between flares and exhaust pipes. (Exhaust gases should not vent directly onto flares)



## TOOLS FOR EASY INSTALLATION

- Electric Drill
- Pop Rivet Gun
- Pencil

---

## FLARE INSTALLATION PROCEDURES

### Step 2a: Attachment (10010/10020) (See Illustrations #1, #2, #3)

- A) Position flare into appropriate wheel well opening and hand hold or C-Clamp in place.
- B) Using indentations formed into flare as a guide, drill and pop rivet Hole #1. Continue to drill and fasten in an alternating pattern until flare is secured. See Illustrations #1, #2, #3.

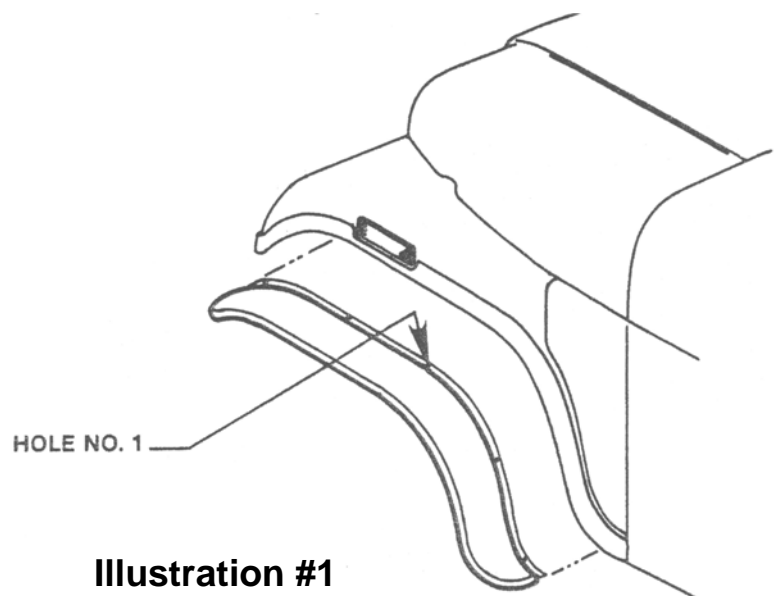

**Step 2b: Attachment (10015)**  
**(See Illustrations #4 & #5)**

- A) With flare off vehicle, pre-drill all pop rivet indents with supplied drill bit.
- B) Position flare into appropriate wheel well opening and hand hold or C-Clamp in place.
- C) Using pre-drilled holes as a guide, mark hole locations onto sheet metal. Remove flare and drill marked locations with supplied drill bit.
- D) Reapply flare, and pop rivet Hole #1. Continue to fasten in an alternating pattern until flare is secure. See Illustrations #4 and #5.

**Note: #10 x 1/2 sheet metal screws may be substituted for supplied pop rivets.**

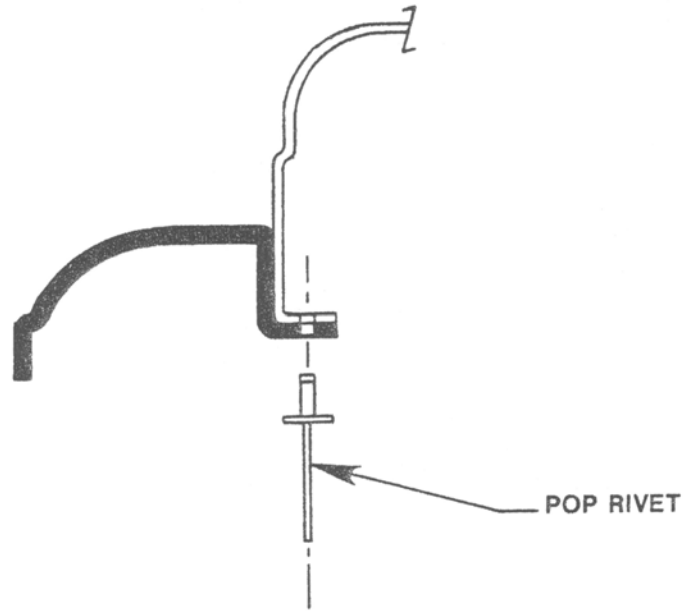

**Illustration #2**

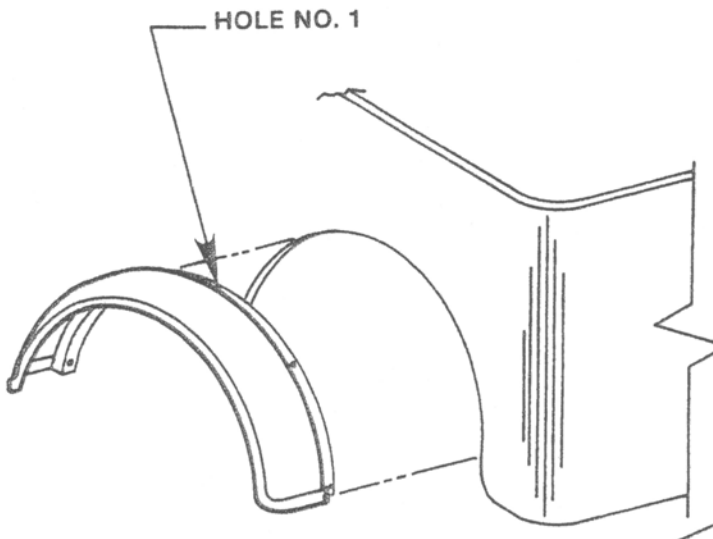

**Illustration #3**

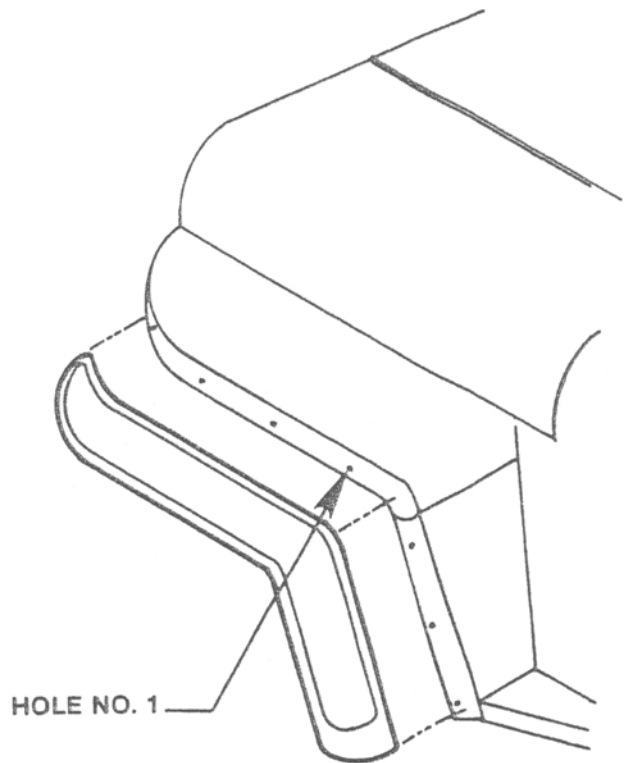

**Illustration #4**

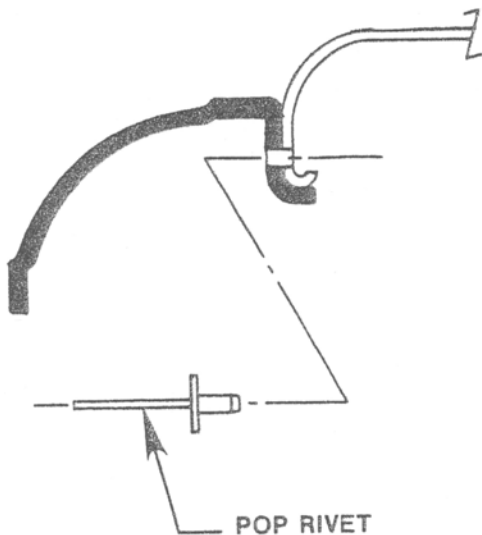

**Illustration #5**